



TROJAN SPECIALTY PRODUCTS

INSTALLATION INSTRUCTIONS 272 WATERER Part #: 12516

Thank you for purchasing the Trojan 272 Waterer. To prepare this waterer for use, please refer to the drawing and instructions below.

1. Remove the Top Cover (11052) from the 272 Waterer.
2. Remove plastic bag containing Red Valve (15229) and Valve Bracket with screws (15359)
These two items are already assembled.
3. Attach this assembly to the 272 Waterer body as shown in diagram using the two bolts and nuts provided in plastic bag.
4. Attach Float (16384) to the Red Valve (15229) using wing nut provided on Red Valve.
5. Replace the Top Cover on the 272 Waterer.
6. Attach water supply to the Valve Bracket (15359)

Water supply line can come from either above or below the 272 Waterer.

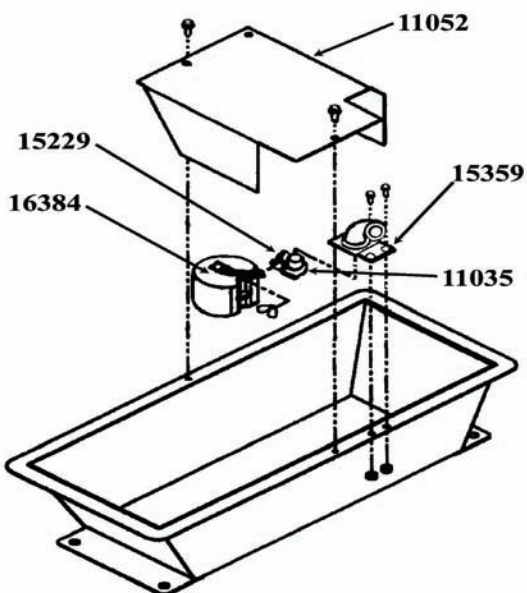

Part #	Description
11035	Valve Rubber (Inside Valve)
11052	Cover
15229	Red Valve Pkg
	contains valve, wing nut and screw
15359	Valve Bracket w/ Screws
16384	Float w/ Arm

WARRANTY FOR TROJAN SPECIALTY PRODUCTS

TROJAN SPECIALTY PRODUCTS, warrants product to be free of defective materials and workmanship. Defective part(s) will be repaired or replaced, at the option of TROJAN SPECIALTY PRODUCTS. This warranty specifically excludes all labor and shipping charges.

This warranty does not apply to any appearance items, to any product whose exterior has been damaged or defaced, to any product subjected to misuse, abnormal service or handling, and to any products altered or repaired with other than original equipment manufacturers parts. The period of warranty begins at original date of purchase and extends for one year.

All warranty claims must be processed thru TROJAN SPECIALTY PRODUCTS.

Beck Sales Company, Inc. 'dba' TROJAN SPECIALTY PRODUCTS
10860 U.S. Hwy 50 — P.O.Box 1735 — Dodge City, Ks 67801
Toll Free: 800-279-1770 — Phone: 620-225-1770 — FAX: 620-225-6521
E-mail: info@becksales.net — Web: www.trojanlivestock.com